

Norsk Data A.S . . . M A N U A L

ND-100 TRACER DESCRIPTION

USER GUIDE

Preliminary

Written: 21.05.1986

Preliminary

.....
THE PRODUCT

The ND-100 Tracer is intended to be a debugging tool for the ND-100 and the ND-110 bus system. It is based upon two cards:

- ND-100 Tracer 3092.
- ND-100 Trace Adapter 3116.

THE READER

The readers of this manual is system programmers and system service personnel. Mainly designers and support people on SINTRAN, XMSG and similar products. Also persons involved in building up ND-100 or ND-110 system can use this tool in troubleshooting activities. Education on ND-100 functionality and SINTRAN design.

PREREQUEST KNOWLEDGE

The reader is assumed to have a general knowledge about the ND-100 and the ND-110 functionality and the bus system used for those computers.

THE MANUAL

This manual is a product description and operation instruction for the ND-100 Tracer.

Chapter one

This chapter gives a functional introduction to the product.

Chapter two

Chapter two contains physical specifications.

Chapter three

This chapter tells how to install the Tracer into a ND-100 or ND-110 computer.

Chapter four

Chapter four is a functional description of the Tracer based on a block diagram.

Chapter five

This chapter tells about what the Tracer can do and how to use it. It also contains software implemented commands description.

Preliminary

TABLE OF CONTENTS

| | | | |
|-------|--|-------|----|
| | | | |
| 1 | PRODUCT INTRODUCTION | _____ | 1 |
| 1.1 | ND-100 Tracer Introduction | | 3 |
| 1.2 | Features of the Tracer. | | 3 |
| | Main parts of operation: | | 4 |
| | The usage of the Tracer: | | 4 |
| 2 | ND - 100 TRACER SPECIFICATIONS | _____ | 7 |
| 2.1 | Physical description | | 9 |
| 3 | INSTALLATION DESCRIPTION | _____ | 11 |
| 3.1 | ND-100 Installation | | 13 |
| | Installing procedure | | 13 |
| 3.2 | ND-110 Installation | | 14 |
| | Installation procedure | | 14 |
| 4 | ND-100 TRACER FUNCTIONAL DESCRIPTION | _____ | 15 |
| 4.1 | Block diagram presentation | | 17 |
| | The MC68000 processor | | 18 |
| | ND-100 Bus interface | | 18 |
| | MMS Interface | | 18 |
| | The Trigger and Qualifier | | 18 |
| | DMA control | | 18 |
| | Valid Data/Address latch | | 18 |
| | The I/O Control | | 18 |
| | The Internal Control | | 19 |
| | The trace function and the Trace RAM | | 19 |
| | The Multiplexer | | 20 |
| | The Eprom/Ram unit | | 20 |
| | The Timer | | 20 |
| 4.2 | The Trace RAM word configuration | | 20 |
| | QUALIFICATION | | 21 |
| | TRIG Specification | | 21 |
| 5 | TRACER USER GUIDE | _____ | 25 |
| 5.1 | ND-100 Tracer Modes of operation | | 27 |
| 5.2 | Local mode of operation | | 28 |
| 5.2.1 | Introduction | | 28 |
| 5.2.2 | Commands | | 28 |
| | How to start! | | 29 |
| 5.2.3 | Normal Operation | | 30 |
| 5.2.4 | Monitor commands detailed description. | | 32 |

| | | |
|-------|---|----|
| | Subcommands | 33 |
| 5.2.5 | Commands to look around in the Trace Memory | 42 |
| | Trace Memory Registrations | 42 |
| 5.3 | Remote Mode Of Operation | 45 |
| 5.3.1 | Introduction | 45 |
| 5.3.2 | Commands in Remote Mode | 45 |
| | Commands not available in remote mode. | 45 |
| | Changed commands in remote mode. | 45 |
| | Extra commands in remote mode | 46 |
| 5.3.3 | Switching between LOCAL and REMOTE mode | 48 |
| 5.3.4 | Installation and requirements to run in REMOTE mode | 48 |
| 6 | TELEFIX CONNECTION <hr/> | 51 |
| 6.1 | Why use Telefix ? | 53 |
| 6.2 | Telefix connection | 53 |

I PRODUCT INTRODUCTION

Preliminary

Preliminary

1.1 ND-100 TRACER INTRODUCTION

Debugging tool

MC68000

MONITOR

The ND-100 TRACER is intended to be a software debugging tool, and can be used for the ND-100 and the ND-110 computers. For the ND-100, both the ND-100 Tracer and the ND-100 Trace Adapter cards have to be installed. The ND-100 Trace Adapter card is an interface to the MMS (Memory Management System), and the test plug (E-bus) is used for this connection. When debugging the ND-110 system only the ND-100 Tracer have to be installed. (The MMS on E-bus). The module has a MC68000 microprocessor with local EPROM, RAM and a Trace Memory. The MC68000 is controlled by a MONITOR residing in a PROM. The user communicates with the Tracer through a Tanberg Notis terminal connected to the front of the Tracer printed circuit board. The Trace Module can be placed into the ND-100 card crate, and connection to TELEFIX communication line is implemented.

1.2 FEATURES OF THE TRACER.

The ND-100 Tracer can stop the ND-100/110 on any combination of physical address and data on the ND-100 bus. The Break (Trig) condition can be:

- IOX accesses.
- CPU Read or Write accesses.
- DMA Read or Write accesses.

These conditions can be done on all or certain levels. CPU addresses can be Physical or Logical. The ND-100 Tracer has a 4K Trace Memory containing what kind of ND-100 instructions that has been executed. For each memory reference or IOX cycle on the ND-100 bus (except memory refresh) 80 bits of information about this cycle can be stored into the Trace Memory. The collection of these data are done without interfering the bus activity in any way. It can run DMA, and be used as a performance analyzer. The last feature can be used when measuring time between programmed events.

Preliminary

MAIN PARTS OF OPERATION:

The MONITOR translates bit numbers and values in the Trace Memory and TRIG/QUALIFICATION masks into symbolic names and numbers that the user can understand better.

Operation examples:

Address bits are operated on as 16 bits logical and 24 bits physical address integers. Data fetched as instructions from the ND-100 CPU, are disassembled. The specification of TRIG/QUALIFICATION conditions and displaying the Trace Memory are done by editing screen oriented menus and pictures.

Exampel of part of the Trace Memory display:

```

*****                               ND-100 TRACER CONTENT                               *****
REL.          P          L I R D I A I P
TO   PHYSICAL I LOGICAL   EXTRA FORMAT   E O / M / P O O TIME
TRIG. BANK. ADDR. T  ADDR.  DATA      DATA      V X W A D T N N INTERVAL
-----
-0007 001 105050 00 025050 140065 SKP IF DA EQL ST 01  R  I  I P 0000 mic.
-0006 001 105052 00 025052 044320 LDA *-060      01  R  I  I P 0000 mic.
-0005 001 104772 00 024772 000000 ==> &@&@  01  R  D  I P 0000 mic.
-0004 001 105053 00 025053 135124 JPL I '+124    01  R  I  I P 0001 mic.
-0003 001 105177 00 025177 021141 ==> " a      01  R  D  I P 0001 mic.
-0002 000 021141 00 021141 150405 PIOF      01  R  I  I P 0001 mic.
-0001 000 021142 00 021142 006000 STA ,X +000    01  R  I      0002 mic.
T0000 000 000001 00 000001 000000 ==> &@&@  01  W  D      0000 mic.
+0001 000 021143 00 021143 150412 PION      01  R  I      0000 mic.
+0002 000 021144 00 021144 146142 COPY SL DP  01  R  I  I P 0006 mic.
+0003 001 105054 00 025054 124002 JMP '+002     01  R  I  I P 0001 mic.
+0004 001 105056 00 025056 124100 JMP '+100     01  R  I  I P 0001 mic.
+0005 001 105156 00 025156 040226 MIN *-152   01  R  I  I P 0001 mic.
+0006 001 105004 00 025004 151243 ==> R #      01  R  D  I P 0001 mic.
+0007 001 105004 01 025004 151244 ==> R $      01  W  D  I P 0000 mic.

```

THE USAGE OF THE TRACER:

- It can be used together with a program listing to follow the sequence of program execution around a TRIG condition.

- The ND-100 TRACER can be used to "freeze" a ND-100 system when a special event occurs. The tracer can STOP ND-100 when a TRIG occurs. The tracer can TRIG when ND-100 STOPS.
- It can be used as a tool when debugging some hardware errors. (CPU errors, DMA devices behaving strange, overwriting of memory, memory out of range errors, IOX errors etc).
- It can measure the approximate time interwall between special events. (Some types of performance measuring, time consumption of special parts of code or debugging asynchronous time critical events.)
- The most obvious area of use for the tracer is as a tool in debugging and documentation of bugs in a ND-100 operating system (SINTRAN, XMSG...).

Memory and register dump can tell quite a lot of the state of a "frozen" system. (The datastructure in memory can be inspected.)

The Trace Memory content can often tell the story that lead to this situation. (Sequence of intructions, addresses, levels, pagetables...). Together they can help support people to get an overview of the error and guide them through the listing easier. Also people that don't know the code and datastructures in detail.

The Trace Memory contain 4096 bus cycles and by a reasonable QUALIFICATION they can contain relevant information about the reason for the error. (ex. ignore the idle loop on interrupt level 0).

- It can be used by non experts to transport information to experts about system stops or other errors. The tracer can be run in REMOTE mode over a modem and the expert can run the tracer from his office on a machine anywhere. The expert can inform a service person what he shall

Preliminary

trig on (or send him a file with a TRIG/QUALIFICATION setup). Then he can bring the Trace Memory content back on a floppy to the expert.

Preliminary

2 ND - 100 TRACER SPECIFICATIONS

Preliminary

Preliminary

2.1 PHYSICAL DESCRIPTION

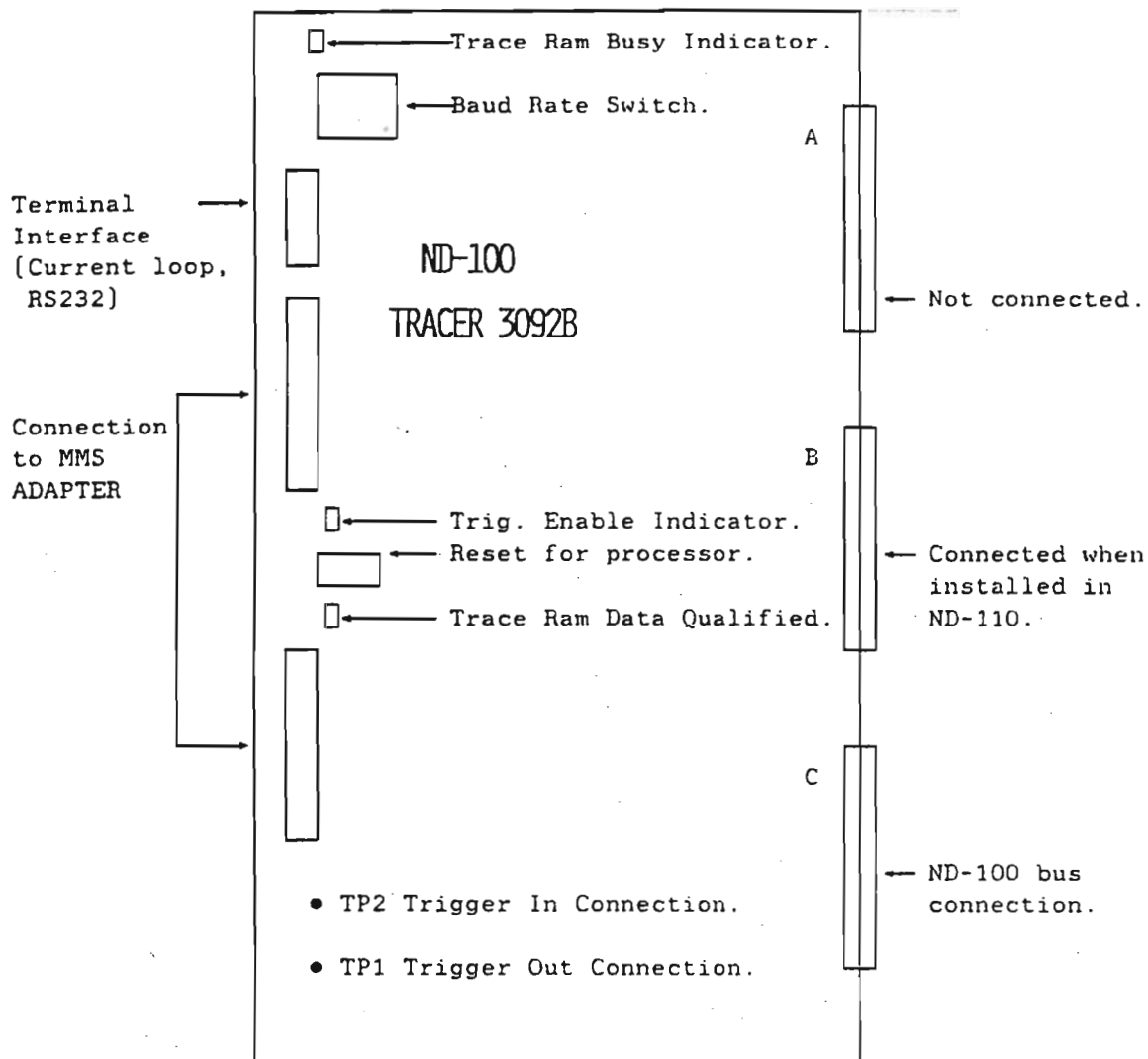

BAUD RATE SWITCH SETTINGS.

| Pos. | Baudrate | Pos. | Baudrate | Pos. | Baudrate | Pos. | Baudrate |
|------|----------|------|------------|------|----------|------|----------|
| 0 | 110 | 4 | 1200 | 8 | 2400 | 12 | 75 |
| 1 | 150 | 5 | 1800 | 9 | 600 | 13 | 50 |
| 2 | 300 | 6 | 4800 | 10 | 200 | 14 | 100 |
| 3 | 2400 | 7 | •• 9600 •• | 11 | 134.5 | 15 | 100 |

Preliminary

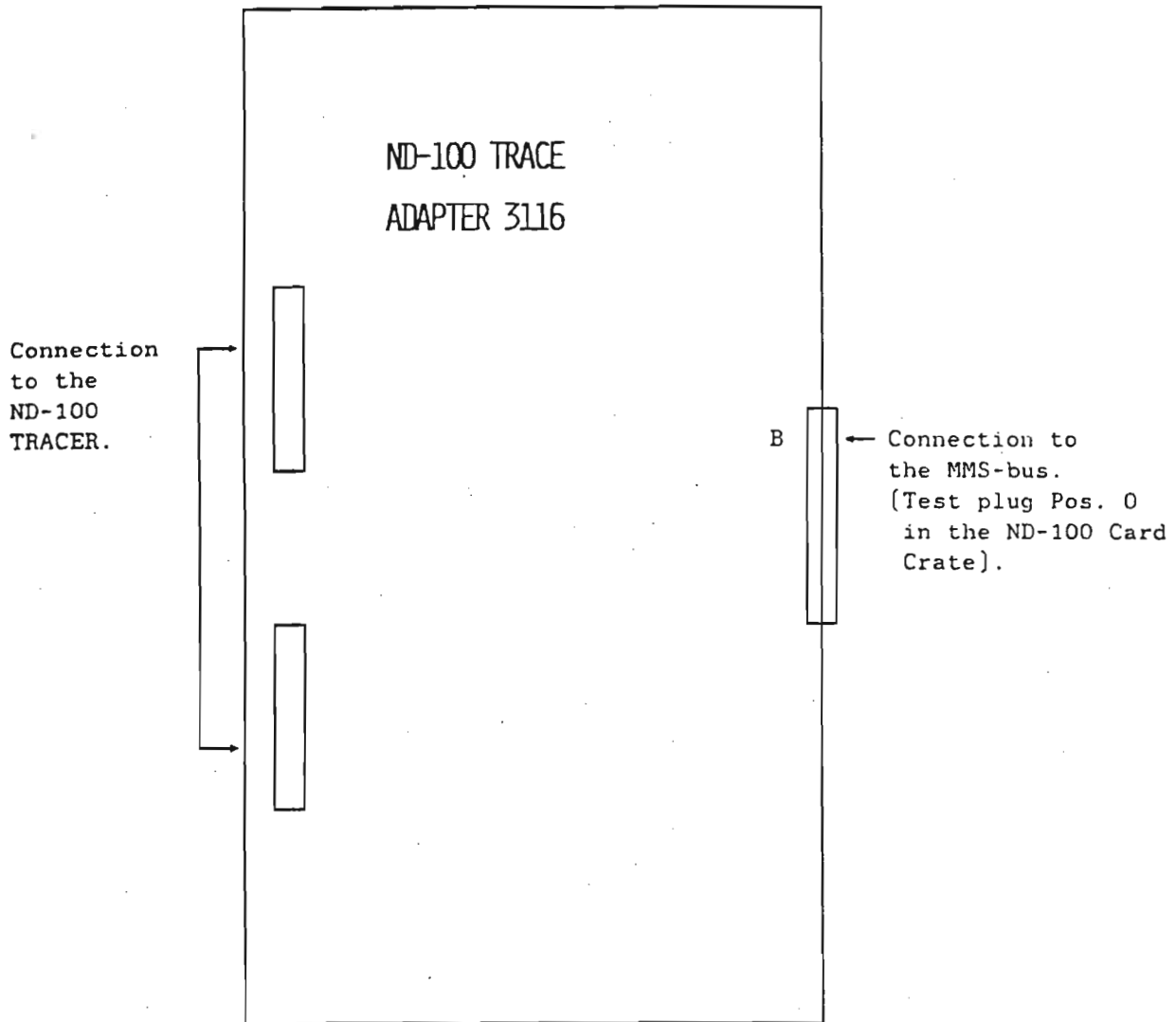

The ND-100 Tracer Adapter is used as an interface to the MMS-bus in the ND-100 computer system. Unlike the ND-110, the ND-100 has one extra card for the MMS. Due to this fact, only the test connector (MMS-bus) in position 0 in the Card Crate is used.

Preliminary

3 INSTALLATION DESCRIPTION

Preliminary

Preliminary

3.1 ND-100 INSTALLATION

Installation of ND-100

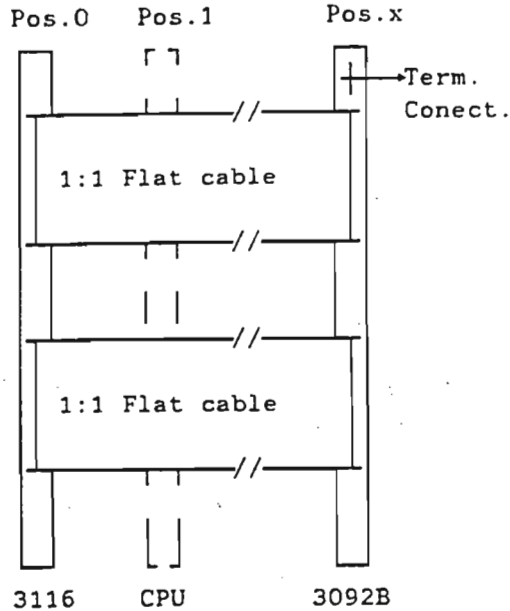

This illustration tells about how to install the debugging tool into a ND-100 computer. The card positions are numbered as in the ND-100 Card Crate, and Pos.x should be the first free position.

The figure is a front view of the cards placed in the Crate. The pos.0 is the test plug position.

INSTALLING PROCEDURE

Large cabinet (22 pos):
Small cabinet (12-pos)
except Compact and Satellite

- 1. Stop the system.
- 2. Protect disks.
The protect switch is located at the front of the disk drives.
- 3. Turn the power off.
The power switch is located at the front panel.
- 4. Install 3116 in position 0.
- 5. Install Terminal cable.
If current loop: Part no. 325307.
If RS232 : Part no. 325303.
- Turn the power on.
- Do a reset on 3092B.

Preliminary

3.2 ND-110 INSTALLATION

Installation of ND-110

Pos. 1 Pos. 2 Pos. 3 ---

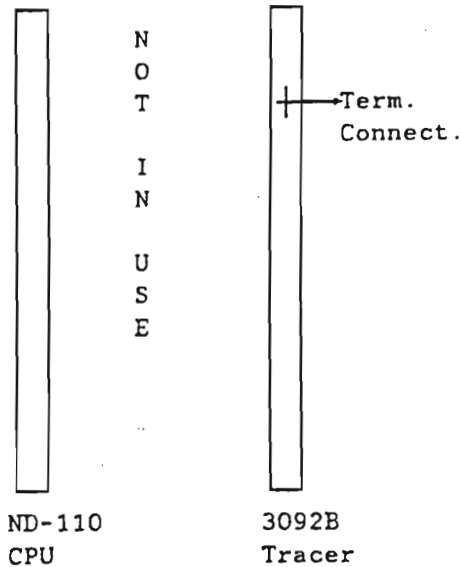

The illustration shows the installation of the debugging tool in a ND-110 computer. The 3116 card is not needed because the MMS connection is done via the B-connector. The MMS-bus should be connected between position 1 and 3.

The figure shows a front view of the cards placed in the Card Crate.

INSTALLATION PROCEDURE

Make sure that the MMS bus is present between pos. 1 and 3.

Large cabinet (22 pos):

- 1. Stop the system.
- 2. Protect disks.
- 3. If ND-110 placed in position 3:
Remove ND-110 from position 3.
Install ND-110 in position 1.
- 4. Install the Tracer (3092B) in pos. 3.
If position 3 is occupied by a memory module, move it to the first free position.

**Small cabinet (12 pos):
Compact and Satellite**

- 5. Install the Tracer (3092B) in position 2.

Preliminary

4 ND-100 TRACER FUNCTIONAL DESCRIPTION

Preliminary

Preliminary

4.1 BLOCK DIAGRAM PRESENTATION

Preliminary

THE MC68000 PROCESSOR

The ND-100 Tracer is using a standard 68000 microprocessor with 8 Mhz clock frequency. The design is similar to the MFbus Controller 3156. The processor has its own clock/interrupt chip (MM58274) with battery backup. Due to this fact it is possible to know the times when the trace function is started and when a trigger (break) has occurred.

ND-100 BUS INTERFACE

The ND-100 interface consists of latches for address and data lines. Transievers for ND-100 bus control signals is also imlemented.

MMS INTERFACE

This interface consists of latches for MMS-bus physical address and data lines.

THE TRIGGER AND QUALIFYER

The Trigger and the Qualifuer is similar in Hardware design. These two units can be programmed to recognize any combination on the ND-100 bus or MMS bus. The data witch will be stored in the Trace RAM, is dependent of the combination the user has made in the software commands available. Refer to the Commands spesified in ch. 5.

DMA CONTROL

This unit isused to control the DMA feature of the Tracer.

VALID DATA/ADDRESS LATCH

This part is used together with the DMA control to store data and address in a DMA operation. A DMA operation means that any physical memory can be read in the ND-100 memory range.

THE I/O CONTROL

THE INTERNAL CONTROL

This part consists of control signals decoding. The control word for the trace part of the Tracer is derived from here. Some enable signals is also implemented as seen in the block diagram.

THE TRACE FUNCTION AND THE TRACE RAM

A control word (16 bits) and a status word (8 bits) are implemented to control the trace part of the controller. The status part will be handled in the software description part in ch. 5. When starting a trace function the control word will enable the ND-100 bus. Different control signals will latch the address and data at the address and data valid times. A signal derived from the MMS command code will latch the information coming from the MMS-bus. This information can be:

- Logical addresses.
- Levels of operation.
- Page tables.
- ION and PON.
- Instruction fetch.
- CPU or DMA select bit.

This trace information will be written into the Trace RAM (4K x 80 bits) in a five word pattern. Each word consists of 16 bits (80 bits together). The Trace RAM works as a ring buffer and the address will be incremented if the data coming in is qualified. If the Trigger unit recognize a trig word, it will be sent to some PAL (Programmable Array Logic). This PAL decides to stop collecting data after a specified time or also stop the ND-100/110 if wanted.

THE MULTIPLEXER

The multiplexer is operated from the internal processor part of the Tracer. To make read and write operations to the Trace RAM, the multiplexer unit is used. It reads or writes one word at a time. Write operations are done for test and initialization purposes.

THE EPROM/RAM UNIT

The size of the local EPROM and RAM units are 96 Kbytes and 16 Kbytes. The implementation is similar to the MFbus Controller card 5156.

THE TIMER

The Tracer provide a possibility to measure the time between every qualified event on the ND-100 bus or the MMS bus. This means that it should be possible to measure the time an interrupt is off or the time a certain routine is using. Some considerations should however be taken. The timer operates in hole time units and starts with microseconds. After 1000 microseconds it starts counting milliseconds and so on. This means that the accuracy will be bad on low figures. But figures between 100 - 990 should be selected as suitable range.

4.2 THE TRACE RAM WORD CONFIGURATION

The Trace RAM is five words wide (80bits) and 4K deep. It is used to collect information about ND-100 bus cycles.

The 80 parallel bits in the Trace Memory have these functions:

- 16 bits data
- 24 bits physical address
- 6 bits logical page nr.
- 4 bits pagetable nr.
- 4 bits interrupt level.
- 1 bit paging on/off
- 1 bit interrupt on/off
- 1 bit access via normal/alternative page table
- 1 bit Instruction fetch or data access.
- 1 bit CPU or DMA access.
- 1 bit read or write access.
- 1 bit IOX cycle performed.
- 16 bits time information gives interval between qualified events.

QUALIFICATION

Between the Trace Memory and the ND-100 bus there is some programmable hardware "masklogic". One part of these masks can be used as a filter to select only special types of cycles to be stored in the Trace Memory.

Example:

Only DMA cycles or interrupt level 12 activity. This selection is called QUALIFICATION.

TRIG SPECIFICATION

The masks can also be used to set up that a special cycle shall cause a TRIG condition in the tracer.

Example:

A write 0 in physical address 44025b. A TRIG condition informs the tracer to stop collecting data into the Trace Memory either immediately or after a selected number of more QUALIFIED cycles.

Preliminary

All 80 bits in the Trace Memory word (except for time interval bits) can be used to specify conditions for QUALIFICATION and TRIG.

Trace Memory word 1



0 15

This Trace Memory word contains ND-100 bus data bits 0 - 15.

Trace Memory word 2

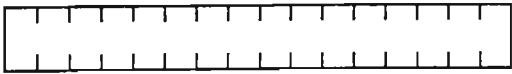

0 15

This word number 2 contains the ND-100 bus least significant address bits 0 - 15.

Trace Memory word 3

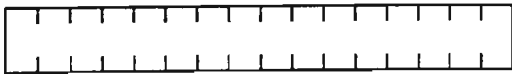

0 15

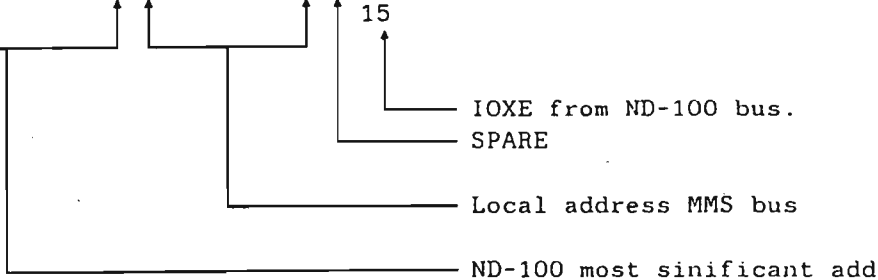

Trace Memory word 4

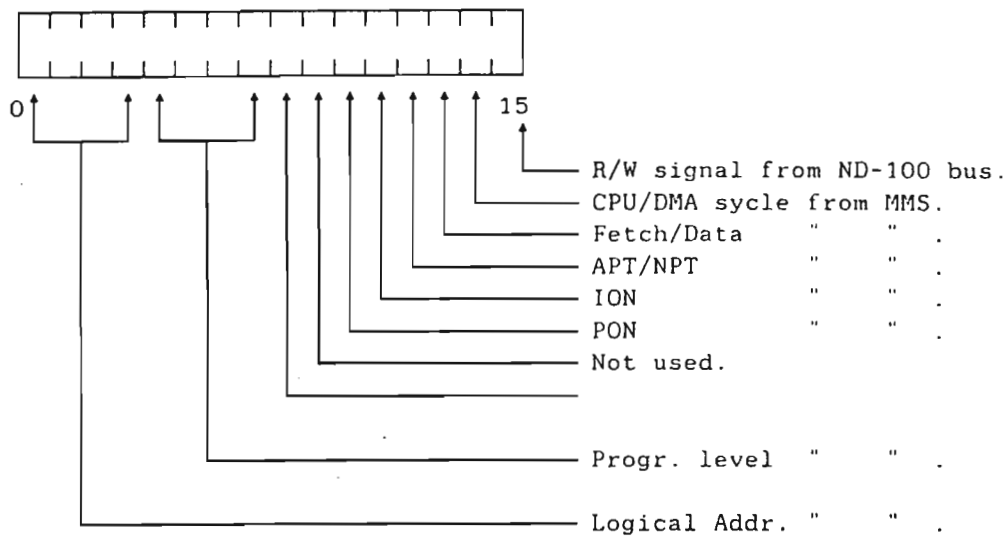

Timer Status Word 5

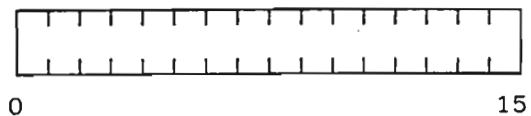

The memory word no 5 contains the local timer information.

Preliminary

5 TRACER USER GUIDE



Preliminary

Preliminary

5.1 ND-100 TRACER MODES OF OPERATION

The tracer monitor can run in 2 modes LOCAL or REMOTE.

Local mode:

Local mode is when a terminal is connected direct to the asynchronous interface plug on the board. Then the monitor performs all the interactive user communication , displays menus, traceinfo etc.

Remote mode:

In Remote mode a cable from the Tracer interface plug is connected to a ND-100 RS-232 interface instead of to a terminal. That ND machine can be the same system as the tracer is plugged into, or another system. Now the tracer is simulated to the user by a ND-100 application program. This program reserves the line connected to the tracer. All the editing and picture display are done in ND-100 and only packed datablocks containing Trace Memory content, setup information , status, and commands are passed between the tracer and ND-100.

The advantage of REMOTE mode is that tracer setup and Trace Memory content can be saved on diskfiles for later inspection and documentation of special conditions. In LOCAL mode the Trace Memory content are destroyed when power is turned off the system.

5.2 LOCAL MODE OF OPERATION

5.2.1 INTRODUCTION

The monitor is residing in PROM and is running on the MC68000 microprocessor on the tracer. The operator communicates with the monitor through a Tandberg Notis terminal connected to a interface on the board. The monitor are ment to help the operator to specify the qualification and trigconditions he wants and to display the tracedata after a trig. This is done by a set of screen oriented menus and pictures. Most pictures have a command input line at the bottom of the screen . Available commands in the picture will then be displayed by the command HELP. Commands can be abbreviated after the same rules as in SINTRAN.

NOTE!

This part refers to the monitor working in LOCAL MODE !

5.2.2 COMMANDS

Special editing characters in the command line are :

| | |
|--------------------|--|
| <CTRL> D | : delete current line |
| <CTRL> A and | : delete current character |
| <LEFT> and <RIGHT> | : arrows can be used to move the cursor in the field. |
| <CTRL> R | : typed at any time in the monitor will have the same effect as pushing the reset switch on the board. |
| <HOME>-arrow/<ESC> | : return to main menu. |

Some pictures have no command line . Their funtions are performed by typing the contol characters explained in the information fields in the picture.

IMPORTANT!

The monitor responds on XON/XOFF characters to start and stop the terminal output. This mean that if a XOF (<CTRL> S) is received from the terminal, the monitor output will

Preliminary

"hang" until a XON (<CTRL> Q) is received.

How TO START!

The main menu should be displayed on the connected terminal after one of the following conditions:

- Power up.
- The reset switch on the board are pushed.
- <CTRL>.R are typed on the terminal.

If no response!

Check that a correct terminal cable are connected and that the baudrate setting are the same on the board and in the terminal.

```

      M A I N   M E N U

  AVAILABLE COMMANDS :
  HELP
  SPECIAL-FUNCTIONS
  TRIG-CONDITIONS-SELECT
  QUALIFICATION-SELECT
  START-TRACE
  DISPLAY-TRACE-CONTENT
  DUMP-PHYSICAL-MEMORY
  MAINTENANCE
  CTRL <R> = RESTART

```

Preliminary

5.2.3 NORMAL OPERATION

Before starting the trace function the operator should decide 2 things.

- What do I want to fill the Trace Memory with (QUALIFICATION).
- Which condition(s) shall cause the tracing to terminate (TRIG).

QUALIFICATION-SELECTION

[Examples]:

- Everything is collected(default).
- Collect all activity except level 0 (idle loop).
- Collect only level 14 code and data.
- Collect only pagetable 5 and 7 on level 1.
- Collect only DMA cycles.
- Collect only IOX cycles.
- Start collecting trace information and wait for trig only after 40405B is written into physical address 7 (ARM function).....

TRIG-CONDITION-SELECTION

[Examples]:

- No trigcondition (default).Tracing stops by manual break only.
- Trig if ND-100 stops.
- Trig if bit 5 is set in the data read in by IOX 502 .
- Trig if anything is written into physical address area 20023B-20175B.
- Trig if anything but 12 is written to or read from logical address 23054B on pagetable 7.
- Trig if interrupt is turned off more than 400 milliseconds .

Preliminary

- Trig if -1 is written into one of the entries in the pagetables.
- Trig if a sequence of upto 4 specified events occurs .

These are only a few examples. The parameters for specifying qualification and trig conditions can be combined together by some rules to specify a large number of combinations.

Spesifying Conditions!

In most occasions the trig-conditions are specified by the TRIG-CONDITION-SELECT command and qualification by the QUALIFICATION-SELECT command. Each will display a picture where you can specify values (or don't care) for data ,address and "control bits". It can be specified upto 4 independant conditions for both trig and qualifications. The selection pictures have two main modes with different fields for cpu addresses :

- PHYSICAL ADDRESS MODE: containing physical address and bank number.
- LOGICAL ADDRESS MODE: containing logical address and pagetable number.

Before the tracing is started you must first answer three questions:

- Shall the tracer STOP the ND-100 cpu when a TRIG occurs?
- Shall the tracer TRIG if ND-100 STOPS?
- Shall the tracer stop collecting data immediately when a trig occurs (end trace), or shall it continue to collect a specified number of cycles?

When the specification part is ready the tracing can be started by the START-TRACE command.

Then the tracer goes into a "collect trace mode". The state of tracing and time are displayed continously. This will continue until a TRIG occurs or it is aborted manually.

Inspecting the data:

When some data are collected in the Trace Memory, it can be inspected by the DISPLAY-TRACE-CONTENT command.

Preliminary

This will start by display 17 entries around the trig point or up to where the trace was aborted. Then you can move forwards or backwards in the Trace Memory by using the arrows keys or by a MOVE-TO command. If you are looking for anything special you can use the commands GET-FORWARDS or GET-BACKWARDS to set up a value or mask to search for in the Trace Memory.

If you are running in remote mode (through the TM-MONITOR program in a ND system) the tracbuffercontent can be copied from the tracer board and saved on a file for later inspection.

ND-100 Memory inspection:

Physical memory in ND-100 can be inspected by the DUMP-PHYSICAL-MEMORY command (only valid in local mode). This command have the same subcommands as DISPLAY-TRACE-CONTENT for navigating and searching.

5.2.4 MONITOR COMMANDS DETAILED DESCRIPTION.

The parameters and functions that are most rarely used or most difficult to use or undestand are put into a separate menu called SPECIAL-FUNCTIONS. Examples are: sequence trig, arm function, pagtable accesses, intervalls... If any of the commands under SPECIAL-FUNCTIONS are to be used they must be specified before the normal TRIG-CONDITION/QUALIFICATION selection.

Special Functions:

This command call up a menu of subcommands. It contain parameters for qualification and trigcondition spesification that are put in on request from very limited usergroups. Some of them may require special knowledge of ND-100 or the tracer. Some command are put here because the use of them are dependant of or put limitations on other parameters. If you think you can achieve the desired result by editing QUALIFICATION-and TRIG-CONDITION-SELECT pictures YOU CAN JUST FORGET THIS COMMAND. If any of the commands under SPECIAL-FUNCTIONS are to be used they must be specified before the normal TRIG-CONDITION/QUALIFICATION selection.

Some of the subcommands can not be mixed and therefore they are separated in groups A,E,

Preliminary

and C. You can select maximum one subcommand from each group.

SUBCOMMANDS

Reset All-Special Functions:

Function: All previously specified special-function parameters are ignored.

Page-Table-Access-Only-Mode (group: a).

Function: When this mode is set the data and addresses are taken from the B-connector of the ND-100 cpu and not the ND-100 bus. Only references in the page index tables in the memory management system will be checked by hardware for qualification, trig, and collected in Trace Memory. It can be used if you have overwritings in the pagetables to stop the ND-100. The Trace Memory will not contain the rest of the memory references of the program that writes in the pagetables. To find the reason this type of error OPCOM has to be used from the CPU console to dump registers and active level.

Limitation: This function can only be used when connected to a ND-100 cpu (not ND-110 series).

Qualify-Data-Different-Than (Group: B).

Parameters: 16 bits octal data value.

Function: When this mode is set the DATAfield of the QUALIFICATION-SELECT picture are taken as an inverted value.

Example

If 0 is set in the datafield, only bus cycles that matches the rest of the qualifier word and have a datavalue different than 0 will be collected in the Trace Memory.

Sideeffects: when this parameter is set only 1 qualifier word can be used in QUALIFICATION-SELECT picture (in normal mode upto 4 words).

Qualify-Data-Interval (Group: B.)

Parameters: lower limit and upper limit as 16 bits octal data values.

Function: When this mode is set the DATAfield of the QUALIFICATION-SELECT picture are taken as an intervall.

Preliminary

Example

If 123B is set in low limit and 374E is set in upper limit, only bus cycles that matches the rest of the qualifier word and have a datavalue between 123B and 374B be collected in the Trace Memory.

Limitations: Not all combinations of lower and upper limit can be used. The qualification "mask logic" has no lower and upper limit registers so the specified intervall have to be checked and maybe split up by the monitor to find a valid set of bitmasks. Some intervals are not possible to represent by the 4 available qualifier word and then the monitor will display the message: 'Interval use too many select words!'. Then you have to try to change one of the limits. (The algorithm for calculating the bitmasks from the intervall is quite complex. Therefor it is difficult to put up a rule for wich intervalls are allowed. It is dependant of both the size and limit values. The user are requested to use the "try and see" strategi. Tip :all intervalls starting at 0 or ending at -1 are allowed.)

Sideeffects: when this parameter is set only 1 qualifier word can be used in QUALIFICATION-SELECT picture (in normal mode upto 4 words).

Qualify-Logical-Addr-Interval
Qualify-Physical-Addr-Interval
[group: b).

For both these subcommands parameters, functions, limitations, and sideeffects are the same as for QUALIFY-DATA-INTERVAL only referring to logical address or physical address instead of datafield.

Extra limitation: For LOGICAL-ADDR-INTERVALL the intervall can not cross a page limit

Extra sideeffect: When one of these fields are used it is not possible to switch between logical and physical address mode in the QUALIFICATION-SELECT picture.

Arm-By-First-Qualifier-Word
[Group: B).

Function: When this mode is set, the 1 qualifier word in the QUALIFICATION-SELECT picture are taken as an ARM word. This mean that no check for trig condition and no collection of tracedata are performed before a buscycle matches within the ARM word.

Preliminary

Trig-Data-Different-Than
[Group: C].

Parameter, function, and sideeffects are the same as TRIG-DATA-DIFFERENT-THAN except referring to TRIG data instead of QUALIFY data.

Trig-Data-Interval
Trig-Logical-Addr-Interval
Trig-Physical-Addr-Interval
[Group: C].

Parameter, function, limitations, and sideeffects are the same as for the corresponding QUALIFY INTERVALLS only referring to TRIG-CONDITION specifications instead of QUALIFICATION.

Sequence-Trig
[group: c].

Parameters: Give number of events in sequence? {2-4}:
 Only qualif. events significant {Y/N}?

Function: When this mode is set the tracer will trig only if 2,3 or 4 (specified by the user) immediately following events matches within the specified TRIG words. If 'Only qualif. events significant' parameter is set to Yes then only events matching within the qualification are checked against the TRIG words to increment or reset the sequence counter. The sequence of events do NOT have to match the sequence of specified TRIG words, and the sequence counter will increment each time an event matches the same trigword.

Interrupt-Off-Longer-Than-Trig
[Group: C].

Parameters: 'Max. IOF time = 2**N mic. sec. N= ? {OCT}'

Function: This function can be used to TRIG the tracer when the ND-100 cpu run with interrupt system turned off for longer than a specified period. The time period have to be specified as the power of 2 micro seconds. Ex. values of N : 4=16 mic. sec., 6=64 mic. sec., 20 {OCT} = 65.636 milliseconds...

Give-Level17-Interrupts
[Group: C].

Parameters: Interrupt interval = 2**N mic. sec. N= ? {OCT}'

Function: This function can be used to issue periodic hardware interrupts to ND-100 on level 17B from the tracer. This will only be usefull if you have a direct-task program or driver in ND-100 that should run at a fixed

Preliminary

intervall for performance measurement or any other reason. It also requires that ND-100 have enabled interrupt from level 17B and that the P register and Paging Control Register on level 17B contain correct values. The specification of the period between interrupts follow the same rules as period in INTERRUPT-OFF-LONGER-THAN-TRIG.

EXIT

Function: Return to MAIN MENU.

Trig-Conditions-Select

This command is used to specify combinations of address, data, and control signals that causes a trig condition. It is possible to specify from 1 to 4 independant trig conditions (called "select words").

Each select word is split up in 5 fields. In addition there are two modes of operation:

- Physical-Address-Mode: DATA, PHYSICAL ADDRESS, CONTROL BITS, PHYSICAL BANK NR., and PRIORITY LEVELS.
- Logical-Address-Mode: PHYSICAL ADDRESS and PHYSICAL BANK NR. fields are replaced by LOGICAL ADDRESS and PAGE TABLE.

Switching between PHYSICAL and LOGICAL address mode is done by typing CTRL> A.

The fields DATA, PHYSICAL ADDRESS, LOGICAL ADDRESS and PHYSICAL BANK NR. are integer data that can be specified in one of the radix modes OCTAL, HEXADECIMAL, or BINARY. The radix mode can be changed for each field individually by typing:

- <CTRL> O = OCTAL;
- <CTRL> Z = HEXADECIMAL;
- <CTRL> B = BINARY;

when the cursor is in the field.

In addition to numerical digits it can be typed in "X" as a don't care digit, which will give match for all values of that digit. You may also see digits displayed as "\$". It means that some but not all bits in this digit are don't care bits. This may happen if radix mode are changed on fields with "don't care digits".

Preliminary

The CONTROL BITS field can be seen as a 7 bit binary integer where each bit have a special meaning. The "0" and "1" values have the following meaning for the different bits.

| bit nr. | value. | | explanation |
|---------|--------|-------|--|
| | 0 | 1 | |
| 7 | | IOX | Bit set when an IOX or IOXT cycle are executed. (NOT when the IOX instruction are fetched from memory). NB! For IOX cycles the information in the address field is hardware device number. (Only 10 least sign. bits valid in logical address.). The data field contain the value transfered between the A register and the device . |
| 6 | Read | Write | Bus direction of dataflow. Intruction fetch are always read. |
| 5 | DMA | CPU | CPU or DMA device causing the memory access. NB! For DMA accesses do only, data , bus direction, and physical address, contain relevant information. |
| 4 | Data | Inst. | Memory access decoded as instruction fetch or data. |
| 3 | NPT. | APT. | Data access mapped through NORMAL or ALTERNATIV page table when running in 2 bank mode. |
| 2 | IOF | ION | Interrupt system turned OFF or ON. |
| 1 | POF | PON | Paging system turned OFF or ON. |

Setting a bit to "X" mean "don't" care.

PRIORITY LEVEL and PAGE TABLE fields are represented by one digit for each level or page table. They are edited by setting a "1" or "X" for the values that can cause a trig and a "0" for values that shall be ignored.

The 5 fields for one select word are "ANDed" together. It means that there must be match on all 5 fields at the same time to cause a trig.

If you want to specify more than one trigcondition , the next select word can be edited by typing <CTRL> N . You can move back to the previous word with <CTRL> P and clear current select word by <CTRL> C.

Trig will occur if there are match with

Preliminary

all fields in at least one select_word.

NOTE!

Remember to fill in all fields . If there are "0" in all values of the interrupt level field the select word can never cause a trig (not even for DMA accesses ,IOX accesses or in interrupt off mode.). There are NO warnings if you specify combinations that can not occur.

If you have a ND-100 CPU (not ND-110 CPU) keep the prefetch mechanism in mind (see note under DISPLAY-TRACE-CONTENT) when you set up trig conditions to avoid false triggering.(The instruction after a SKP may be fetched and cause a trig even if it is not executed.)

Exampel of a TRIG-CONDITION-SELECT picture:

```

*****          SELECT  CONDITION FOR TRIG          *****
                                     Control bits
Data          Physical address  0:      Read  DMA  Data  NPT  IOF  POF
16 BITS (BIN) 16 BITS (OCT)  1: IOX  Write  CPU  Inst. APT  ION  PON
00000000000001XX 000207      X      1      X      X      X      X      X
0000000100000000 >000500      1      X      X      X      X      X      X

```

Physical bank nr
8 BITS (HEX)

01
XX

Priority levels

```

15 14 13 12 11 10 9 8 7 6 5 4 3 2 1 0
0 0 X X X X 0 0 0 0 X 0 0 0 0 0
X X X X X X X X X X X X X X X X

```

COMMANDS :

Address mode: <CTRL> A: switch between LOGICAL and PHYSICAL mode.
Radix modes: <CTRL> O = OCTAL, <CTRL> Z = HEXADECIMAL, <CTRL> B = BINARY
Select words: <CTRL> N = NEXT, <CTRL> P = PREVIOUS, <CTRL> C = CLEAR current.
<CTRL> V = X in all fields, <CTRL> F = X in field, <CTRL> D = 0 in field.
Arrows <UP>/<DOWN> between fields,<LEFT>/<RIGHT> within field, <HOME> = EXIT.

Preliminary

This example are set up with two select words. They will cause a trig:

- 1. If a dataword with value from 4 to 7 are written in physical address 207B in bank nr. 1 when running on one of the levels 13,12,11,10, or 5.
- 2. If IOX 500 are executed with value 200B in the A register.

Qualification-Select

This command is used if you want to collect only some of the bus cycles into the Trace Memory. You can collect only level 12 code, only pagetable 5 and 7 accesses, only DMA access and so on. Specification of the QUALIFICATION are done exactly the same way as the TRIG-CONDITIONS.

NOTE!

Trig and qualification are independant. It means that if your specified trig-conditions does not match within your qualifications the tracer will trig but the memory access that caused the trig will not be stored in the Trace Memory.

Start-Trace:

When trig-condition and qualification pictures are edited ready, tracing of memory accesses can be started. This command will first clear old information in the Trace Memory. Then some questions must be answered:

STOP ND-100 if trig ? (y/n):

A 'y' here will cause the tracer to assert the stop signal to the ND-100 CPU when a trig condition occurs. This can be used if you want to look around in the ND-100 memory or display registers that were valid when the trig occurred. The execution of the ND-100 CPU can be continued by typing a "!" on the ND-100 console.

TRIG if ND-100 stops? (y/n): This will be an extra trig condition in addition to the trig-condition select-words . A 'y' will cause a trig in the tracer if the ND-100 CPU stops.

Preliminary

Specify location of trig point in Trace Memory :
Start trace=0. Endtrace = 7777 <OCT> .

Trace Memory

The Trace Memory contain 10000B entries. The tracer can continue to collect a number of qualified bus cycles after a trig condition have occured before the tracing stops. You can here specify the trig point location [between 0 and 7777 octal]. 0 mean that the trig-point is first, 7777 that it is last in the Trace Memory.

When this question is answered TRACING WILL START. The tracing operation will continue until a TRIG occures or it is aborted by the user typing <ESC>. The state of tracing will continously be displayed and can have the following values :

```

*** TRACE RUNNING ***

==> ARM WORD LOADED! WAITING FOR ARM CONDITION
    [Can be seen if special ARM function is used.]

==> WAITING FOR TRIG CONDITION
    [Normal state when collecting data in Trace Memory.]

```

```

*** TRACE FINISHED ***

==> TRIG OCCURED! WAITING FOR Trace Memory TO BE FILLED'
    {Displayed when trig has occured but not enough
    qualified events have occured to fill the rest
    of the Trace Memory. Only seen when not
    'end trace' selected.}

==> TRIG OCCURED! Trace Memory FILLED
    {Normal state after a trig}.

```

```

*** TRACE ABORTED ***
{Tracing aborted by a user break , not by trig.}

```

Preliminary

Display-Trace-Content

After a trace the trace-buffer can be inspected by this command. Exampel of a DISPLAY-TRACE-CONTENT picture.

```

*****                               DISPLAY TRACE CONTENT                               *****
REL.                                  P                                  L I R D I A I P
TO   PHYSICAL  I LOGICAL          EXTRA FORMAT          E O / M / P O O TIME
TRIG. BANK. ADDR. T ADDR.  DATA  DATA                V X W A D T N N INTERVAL
-----
-0007 001 105050 00 025050 140065 SKP IF DA EQL ST 01 R I I P 0000 mic.
-0006 001 105052 00 025052 044320 LDA *-060 01 R I I P 0000 mic.
-0005 001 104772 00 024772 000000 ==> &@&@ 01 R D I P 0000 mic.
-0004 001 105053 00 025053 135124 JPL I *+124 01 R I I P 0001 mic.
-0003 001 105177 00 025177 021141 ==> " a 01 R D I P 0001 mic.
-0002 000 021141 00 021141 150405 PIOF 01 R I I P 0001 mic.
-0001 000 021142 00 021142 006000 STA ,X +000 01 R I 0002 mic.
T0000 000 000001 00 000001 000000 ==> &@&@ 01 W D 0000 mic.
+0001 000 021143 00 021143 150412 PION 01 R I 0000 mic.
+0002 000 021144 00 021144 146142 COPY SL DP 01 R I I P 0006 mic.
+0003 001 105054 00 025054 124002 JMP *+002 01 R I I P 0001 mic.
+0004 001 105056 00 025056 124100 JMP *+100 01 R I I P 0001 mic.
+0005 001 105156 00 025156 040226 MIN *-152 01 R I I P 0001 mic.
+0006 001 105004 00 025004 151243 ==> R # 01 R D I P 0001 mic.
+0007 001 105004 01 025004 151244 ==> R $ 01 W D I P 0000 mic.

```

> _____

All fields except for the time interval field contain OCTAL numbers.

Explanation of the information in the display-trace-content picture:

REL. TRIG:

Show address in trace-buffer relative to the trig-point. T0000 is the trig-point. Negative values are stored before and positive values after the trig-point.

PHYSICAL ADDRESS:

is displayed as BANK number + displacement within bank. (1 bank is 64k 16 bit words.)

LOGICAL ADDRESS:

Is displayed as pagetable number (PIT) + 16 bit logical address. The displacement within page is the same for physical and logical addresses. The logical address is irrelevant for DMA acesses. NB! Pagetable field is not correct when connected to the first version of ND-110 cpu.

Preliminary

DATA:

Is the 16 bits transported to or from memory in instruction fetch, read and write or DMA cycles.

NOTE!

For IOX cycles the information in the address field is hardware device number. (Only 10 least sign. bits valid in logical address.). The data field contain the value transferred between the A register and the device .

EXTRA FORMAT DATA:

contain data disassembled when the instruction fetch bit is set, else ASCII value of the data.

The CONTROL BITS are represented by:

IOX : I or space Read/Write: R
or W DMA / CPU : D or space
Data/Inst.: D or I APT./NPT. : A or
space ION / IOF : I when ION else
space PON / POF : P when PON else
spaceor space

TIME INTERVAL:

Contain approximate information of how long time it has taken since previous qualified memory accesses was stored in the Trace Memory.

When the monitor can not find the trig-point in the Trace Memory it logically uses the last stored entry as trig-point.

5.2.5 COMMANDS TO LOOK AROUND IN THE TRACE MEMORY

TRACE MEMORY REGISTRATIONS

Cache or pagetable accesses

The tracer are only detecting accesses going on the ND-100 bus where it is located. Read or write only in cache or pagetables are not seen. To avoid confusion when looking in the Trace Memory ALWAYS TURN THE ND-100 CACHE OFF BEFORE TRACING IS STARTED.

Preliminary

Prefetch

The normal ND-100 CPU (separate CPU and mms board) are using prefetch on instructions. It means that while one instruction are decoded the next address are fetched as an instruction from memory even if it is really executed or not. This may lead to "false" instructions in the trace after sequencing instructions as JMP, JPL, SKP, MIN, WAIT and so on. The data operated on by an instruction may often lay some location after the instruction in the Trace Memory. Changes in some CPU conditions as paging and interrupt system may cause the microprogram to fetch the same instruction two or three times before it is executed (it can not trust that the prefetch was correct). This mean that the user have to watch the sequence of logical addresses and type of instructions carefully, to sort out manually which instructions have been executed and which are false prefetches. This can be quite difficult if some SKP, JMP and MIN are following in the trace . Prefetching should also be kept in mind when setting up trig conditions to avoid false triggering.

Accesses in shared memory

When the tracer are located on the local ND-100 bus , memory accesses coming from other channels to a shared memory are not seen by the tracer board and therefore not stored in the Trace Memory. This goes for accesses from ND-500 and DMA interfaces located in other crates.

IOX internally on the cpu board

IOX cycles going to the console or the internal realtime clock are not stored in the Trace Memory.

DMA

For DMA accesses only physical address, data, and R/W bit contain relevant information.

NEXT-PICTURE / PREVIOUS-PICTURE (or the <UP> / <DOWN> arrows) will move the display window to the next/previous 20B entries in the buffer. MOVE-TO will move to an absolute octal value in the buffer.

Get-Backwards-Value

Get-Forwards-Value

Will search trough the buffer fora specified combination of addresses, data and control bits.<CTRL> G will continue the search specified in the previous GET command.

Dump-Physical-Memory

The tracer can read the ND-100 memory through a DMA interface that read 1 word pr. transfer. This command can display and decode the content of physical memory . It has the same

Preliminary

subcommands for moving around and searching as the DISPLAY-TRACE-CONTENT command. Moving and searching are done within one 64k word memory bank at a time. And there is a command SET-BANK-NUMBER to move to another bank.

IMPORTANT!

Remember that the tracer act as a normal DMA device on the bus and if you try to read uninitialized or nonexistent memory the ND-100 CPU will get a MEMORY PARITY ERROR or MEMORY OUT OF RANGE internal interrupt and SINTRAN will probably go in ERRFATAL (STOP). Therefore this command must be used with great care when SINTRAN is running.

NOTE!

The last page in bank 0 are never used by SINTRAN and are not initialized except if a memory test program have been run before SINTRAN is started.

Maintenance

This contain some subcommands for verification of the tracer board itself and are not used in normal operation. Commands exist for testing Trace Memory, update internal clock and look at internal program memory.

Preliminary

5.3 REMOTE MODE OF OPERATION

5.3.1 INTRODUCTION

In REMOTE mode a cable from the tracers interface plug is connected to a ND-100 RS-232 interface instead of to a terminal. The ND machine can be the same as the tracer is plugged into or another system. Now the tracer is simulated to the user by a ND-100 application program called TM-MONITOR. This program reserves the line connected to the tracer. All the editing and picture display are done in ND-100 and only packed datablocks containing Trace Memory content, setup information, status, and commands are passed between the tracer and ND-100. The advantage of REMOTE mode is that tracer setup and Trace Memory content can be saved on diskfiles for later inspection or documentation of special conditions. In LOCAL mode the Trace Memory content are destroyed when power is turned off the system.

5.3.2 COMMANDS IN REMOTE MODE

COMMANDS NOT AVAILABLE IN REMOTE MODE.

The commands DUMP-PHYSICAL-MEMORY and MAINTENANCE does not exist in TM-MONITOR program.

CHANGED COMMANDS IN REMOTE MODE.

START-TRACE will send blocks of tracer setup information to the tracerboard. When trace is running it will poll the line to get the state of the tracer. This mean that it takes a short moment from the trig occures until it is reported by the program.

Preliminary

Display-Trace-Content

This command can use two different strategies when displaying and searching through the Trace Memory.

- If COPY-TRACE-FROM-TRACER or READ-TRACE-FROM-FILE command are used, the program's local Trace Memory is always used by GET and display operations.
- If only OPEN-PATH-TO-TRACER command is executed, blocks of Trace Memory Content are fetched over the line when needed for display. If you display the same picture twice no fetching is necessary the second time. GET-FORWARDS/BACKWARD will ask the traceboard to make the search and report back if a match is found.

The second strategy will save the time it takes to copy the entire buffer if you don't want to save it on file, but you may have some extra halts in the display when data is fetched.

EXTRA COMMANDS IN REMOTE MODE**Open-Path-To-Tracer**

Parameter: Peripheral file name of tracer?

Function: This command reserves the periphereal file where the cable from the tracer should be connected. A control character is sent to the tracer to set it in remote mode . Then a message is sent to the tracer to check for responce and get some information about the state of it. If OK the message 'Contact established!' will be displayed. This command must be performed with no errors before the commands START-TRACE, COPY-TRACE-FROM-TRACER or DISPLAY-TRACE-CONTENT are executed.

Copy-Trace-From-Tracer

Parameter: 'COPY ENTIRE BUFFER (Y/n)' If 'N' then in addition 'FROM OCTAL ADDRESS (-7777B:7777B)' and 'TO OCTAL ADDRESS (-7777B:7777B)'.

Function: The content of the Trace Memory in the ND-100 tracer board is copied over the RS-232 line to a memory buffer in the TM-MONITOR program in ND-100. To copy the entire buffer takes approximately 5 minutes on a 9600 baud line. When copying is finished the

Preliminary

user is asked if he wants to save the tracecontent on file.

Save-Trace-On-File

Parameter: FILE NAME. Default file type is :TRAC

Function: Save the content of the local Trace Memory on a file. One such file need 24 pages of disk space.

Read-Trace-From-File

Parameter: FILE NAME. Default file type is :TRAC

Function: Read Trace Memorycontent previously written by SAVE-TRACE-ON-FILE This Trace Memorycontent can now be displayed by DISPLAY-TRACE-CONTENT.

Save-Setup-On-File

Parameter: FILE NAME. Default file type is :STUP

Function: The parameters edited in the pictures SPECIAL-FUNCTIONS, TRIG-CONDITION-SELECT, and QUALIFICATION-SELECT can be saved on a disk file by this command.

Read-Setup-From-File

Parameter: FILE NAME. Default file type is :STUP

Function: A readymade tracer setup written to file by the command SAVE-SETUP-ON-FILE can be read back by this command. When issuing a START-TRACE command this TRIG and QUALIFICATION setup is sent directly to the tracer board without have to be edited. If wanted this seetup can be inspected and modified the normal way.

Print-Trace-On-File

Parameter: FILE NAME. Default file type is :PRNT 'FROM OCTAL ADDRESS (-7777B:7777B)' and 'TO OCTAL ADDRESS (-7777B:7777B)'.

Function: This command produce a file containing a part of the Trace Memory content in a ascii decoded format similar to the DISPLAY-TRACE-CONTENT command. This file can be read by an normal editor or printed on a printer. NB! The printout of an entire tracebufer by this command require 165 pages of disk space.

5.3.3 SWITCHING BETWEEN LOCAL AND REMOTE MODE

Switching the tracer board from local to remote mode are done automatic by the OPEN-PATH-TO-TRACER command in TM-MONITOR program. To switch it back to local mode, when a terminal is connected directly to the board, you can type <CTRL> R on the terminal or push the reset button on the tracer. The trace content is not destroyed by any of these swithing in modes. That means that if you have run in local mode and have got something in the Trace Memory that you want to save, you can connect it in remote mode and use the commands OPEN-PATH-TO-TRACER, COPY-TRACE-FROM-TRACER, and SAVE-TRACE-ON-FILE in the TM-MONITOR program. If you are running the TM-MONITOR program on the same machine as the tracerboard is installed, and the TRIG or a bug makes the system to stop, you can either restart your system or connect the tracer locally to display the trace content.

5.3.4 INSTALLATION AND REQUIREMENTS TO RUN IN REMOTE MODE

Hardware requirements.

- 1 ND-100 TRACER board.
- 1 cable ND100-ND100 RS 232.
- 1 free terminal-line switched switched to RS 232.

The terminal-line should run on the same baudrate as the ND-100 tracer board and with even parity.

Software requirements

The program TM-MONITOR:PROG need 120 pages of disk space. It must be run on a Tandberg NOTIS terminal.

On the logical device number of the terminal-line to the tracer the following procedure must be performed from user SYSTEM.

<DEVNO> should be substituted with the actual desimal logical device number.

Preliminary

```
@SET-PERIPHERAL-FILE "TRACER" <DEVNO>D  
@SET-FILE-ACCESS TRACER RW,RW,RWD  
@SINTRAN-SERVICE @REMOVE-FROM-BACK-TABLE  
<DEVNO>D I Y Y Y @CHANGE-BUFFER-SIZE  
<DEVNO>D I 1000B Y Y Y @EXIT
```

The next lines should be put in LOAD-
MODE:MODE file. (They must be performed for
each warm start.)

```
@SINTRAN-SERVICE  
@CHANGE-DATA <DEVNO>D I Y N N  
ECH/O  
. @EXIT
```

Preliminary

6 TELEFIX CONNECTION



Preliminary

Preliminary

6.1 WHY USE TELEFIX ?

6.2 TELEFIX CONNECTION

Preliminary

